



ITEM #2: for the ARCHITECTURAL COMMMISSION - 5.17.21 @ 7:00 P.M.

REQUEST: Consideration of a request for approval for a replacement sign for “H & I Auto”, (formerly “Auto World USA, Inc”) on property known as 7151 Rt. 83 Unit D, Submitted by Wellcom Signs on behalf of business owner Yunje Kim. .

HISTORY/STAFF REVIEW:

The property in question is located approximately at the southwest corner of Route 83 and Route 45. The property is zoned under the “B-2” Suburban Business District regulations. Petitioner seeks to install a non-illuminated wall sign with a new copy at this location.

The property was the subject of litigation in 1986 and a court order established use of the property as an automotive service & shopping center as well as parameters for signage on the property (excerpt attached). In short, signage for this development deviates from the “B-2” signage regulations found in the Village Zoning Code and are established by the this court order.

The 1986 court order established parameters for two types of signage on the property. One set of parameters was established for the “center sign” which was located in the front of the building on Route 83.

In May of 2016 the AC considered and approved a replacement center sign for the property as the existing sign had aged and become damaged by wind. The AC found the proposed replacement signage was consistent with the court order and were favorable to the more modern look of the proposed sign noting the existing sign looked dated. No changes are proposed to this signage except placard for the business consistent with the signage as proposed

The other set of parameters was for building or tenant signage and are part of this request for signage. These standards supersede the Village Zoning Code in this instance.

Proposal:

Mr. Yunje Kim has now leased the tenant space in Unit D of the building and is requesting signage for his business.

The sign is contemplated to be made of a blue vinyl laminate silhouette letters mounted on 3” aluminum studs. As proposed the signage will be non-illuminated. A rendering of the proposed location of the signage on is attached.

Copy will read “H & I Auto” over the entrance with Korean script over the service bay door indicating “repair auto”.

As proposed letters are 18' inches high which is consistent with court order regarding letter height in height. Exterior signage is non-illuminated and contains no moving or flashing lights which is also consistent with the court order.

As proposed signage appears consistent with the court order and other signage in the development...

ARCHITECTURAL COMMISSION DECISION:

The Commission should review the request for signage in light of the aforementioned of standards as established by the court order and render a determination based upon those criteria. I do not have an "Exhibit J" but it appears to be a signage plan for the entire site including buildings and "center sign.

Client : H&I Automotive 7151 N. Route 83 (Unit #D) Long Grove, IL

"welcome!"
well-communication design

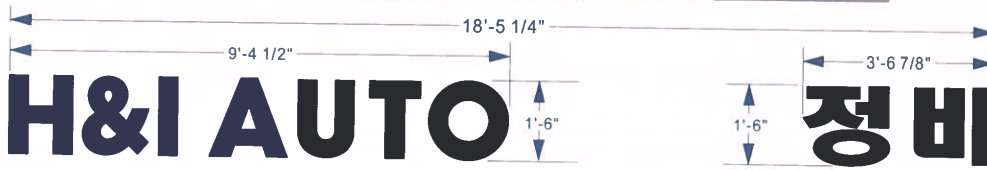
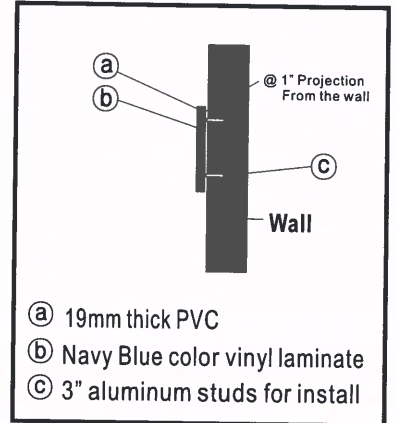

Make & install a set of PVC(19mm) letter non-illuminate sign on the wall with stud mount.

Letter color : Navy blue color vinyl laminate and painted

Customer Approval Signature _____ Date: _____

Landlord Approval Signature _____ Date: 4/30/2021

CUSTOMER	H&I Automotive
COLOR	FACE Navy Blue
DRAWING No.	#042521-01

1840 Industrial Dr. #270 Libertyville, IL 60048 tel: 847.816.1374 Email: wellcomsign@gmail.com

Wellcom Sign

12-16-86

Exhibit C.

6. The hours of operation of all businesses operated on the subject property shall be restricted to 7:00 A.M. through 9:00 P.M.

7. The permitted uses which may be established within the Center shall be as designated by the list of permitted uses (hereinafter "list of uses"), attached hereto as Exhibit F and incorporated herein by reference. Any other uses may be permitted in the discretion of the Village of Long Grove upon application to the Village and approval thereby as a special use.

8. The signage of the center as to size, location, and appearance, shall be in substantial conformance with the signage plan dated December 16, 1986, attached hereto as Exhibit J and incorporated herein by reference, and shall conform to the following criteria:

A. The height shall not exceed 15 feet above grade, and the illuminated portion of the sign shall be no greater than 12 1/2 feet above grade.

B. The type of sign shall be monument only with appropriate landscaping. No poles shall be permitted.

C. All signs shall be illuminated internally only.

D. The maximum square footage of the entrance sign shall not exceed 105 square feet.

E. Only one exterior sign shall be permitted per store except that the anchor tenant may have two signs.

F. All exterior store signage shall be silhouette letters. The letters shall be no greater in height than 18

12-16-86

inches and shall not be illuminated. All exterior store signs shall be of the same style and color, except for recognized National tenants whose signage is determined by Corporate Standards, in which case the color and style of the signage shall be determined thereby.

G. No more than 30% of any store window may be used for interior signage or window signage purposes.

H. All other signs, if any are permitted, shall be subject to the review and approval of the Long Grove Architectural Board.

I. No sign shall have moving parts or flashing lights.

9. All garbage or refuse disposal areas must be totally enclosed and not subject to public view.

10. All businesses located on the subject property shall obtain and maintain Long Grove business licenses.

11. The plaintiff's and their successors, if any, shall maintain, in good condition, the landscaping, fences, signage, and buildings.

12. There shall be no merchandise, supplies or any other materials stored, temporarily or otherwise, outside of the interior of the buildings to be constructed on the Subject Property.

13. Long Grove shall issue all necessary building and all other permits to permit the proposed use upon submission by the plaintiff of plans and specifications required by and in compliance with the ordinances of Long Grove, and upon compliance with all other Long Grove ordinance provisions

← 2018 IL-83 Mundelein, Illinois



2018 IL-83 Mundelein, Illinois

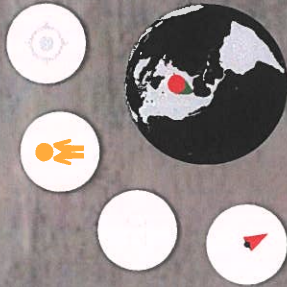
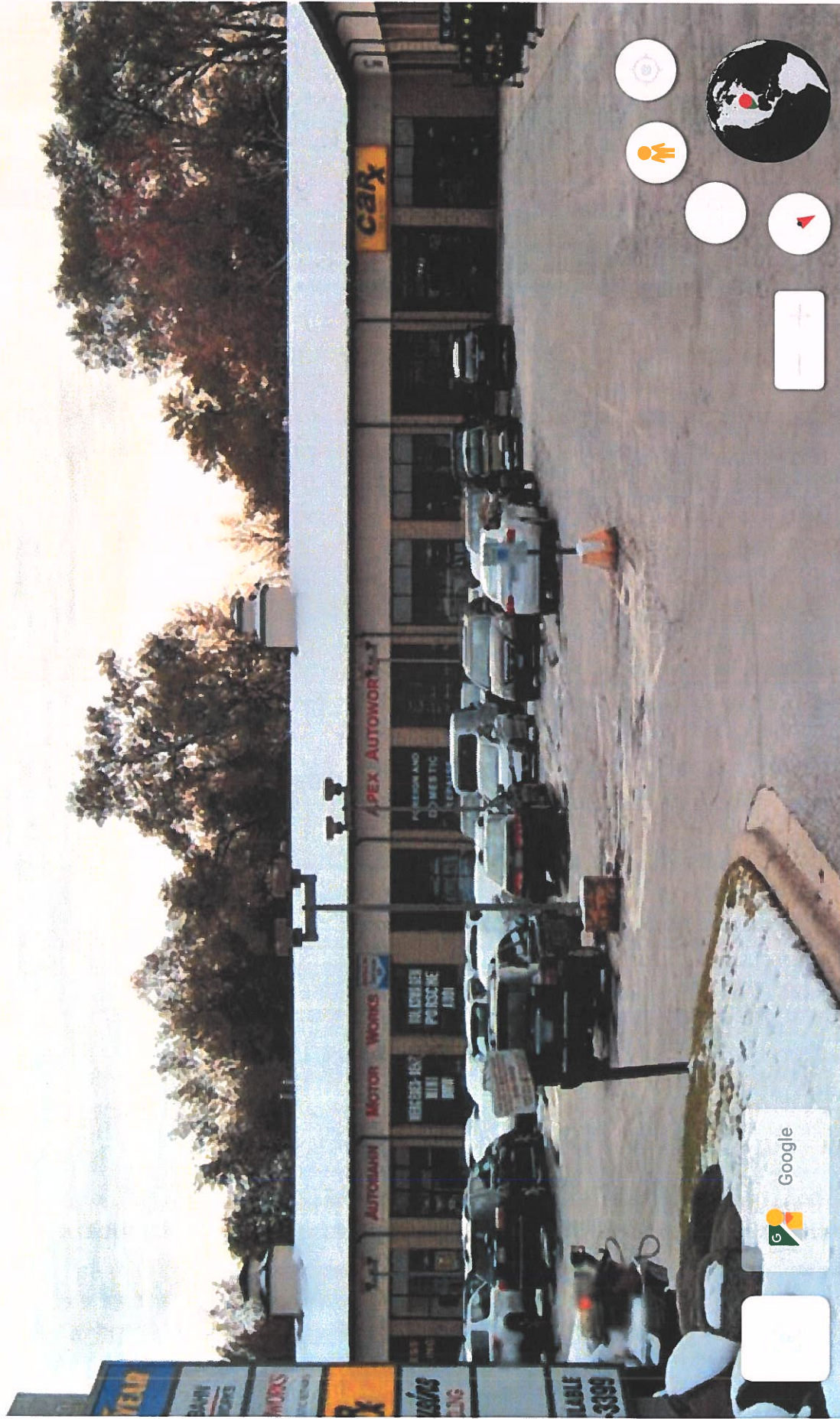

Village of

FOR OFFICE USE ONLY:	
AC Received:	
AC Reviewed:	
AC Approved:	
Village Bd. Approved:	

FOR OFFICE USE ONLY:		
Date Received:		
Permit No.:		
Date Issued:		
Township:		
Sec:	T:	R:
PIN No.:		
Zoning:		

ARCHITECTURAL COMMISSION SIGN PERMIT APPLICATION

BUSINESS NAME: H & I Auto	BUS. PHONE #:
BUSINESS ADDRESS: 7151 N IL Rt 83 - D	
BUSINESS OWNER'S NAME: CB&Q I LLC Yunje Kim	ilikeyunje@naver.com

TYPE OF SIGN(S) FOR WHICH YOU ARE APPLYING:	Wall mounted Sign (19mm thick PVC Letters)
---	--

The Architectural Commission regularly meets every third (3rd) Monday of the month at 7:00pm in the Village Hall or as otherwise posted. The applicant (or representative) must be present. Please prepare and submit seven (7) sets of all of the following information ten (10) days prior to the meeting:

- THIS FULLY COMPLETED APPLICATION SIGNED BY BOTH THE PETITIONER AND THE PROPERTY OWNER
- REGARDING THE POSITION OR LOCATION OF PROPOSED SIGN ON THE BUILDING OR PROPERTY:
 - PROVIDE SITE PLAN
 - PROVIDE PHOTOGRAPH OF THE LOCATION ON THE PROPERTY OR BUILDING WHERE THE SIGN WOULD BE INSTALLED
 - SQUARE FOOTAGE OF COMMERCIAL SPACE FOR WHICH SIGN IS BEING INSTALLED:

394 sq. ft.
- PROVIDE A DETAILED DRAWING (TO SCALE) OF THE PROPOSED SIGN, INCLUDING:
 - DIMENSIONS
 - SAMPLE OF COLORS ON SIGN
 - LETTER STYLE TO BE USED
 - SAMPLE OF ANY UNUSUAL MATERIAL TO BE USED ON THE SIGN
 - FOR REQUESTS IN THE B-1 HISTORIC DISTRICT SEE SUGGESTED DESIGN GUIDELINES FOR SIGNAGE**

Should the sign be completed prior to the Architectural Commission's approval (this is not encouraged), the sign itself, or a photograph of the sign, shall be presented at the Architectural Commission meeting.

SIGN CONTRACTOR:

NAME: Welcom Sign Corp	PHONE #: 847-816-1374
ADDRESS: 1840 Industrial Dr. # 570 Libertyville 60048	E-MAIL: Welcomsign@gmail.com

The property owner's signature is required below before any sign application may be processed. The property owner's signature is confirmation that he/she has read and understands the regulations governing the erection of signs in the Village of Long Grove and further approves the erection of the above-described sign on his/her property.



PROPERTY OWNER(S) SIGNATURE(S)
Patrick Stavros
PROPERTY OWNER(S) PRINTED NAME(S)
BUSINESS OWNER(S) SIGNATURE(S)